

AE ADAM

Adam Equipment

TFC SERIES

Software rev.: 134-68

ADAM EQUIPMENT CO. LTD.
p.n. 3939, Revision E, February 2004

Changes made in this revision with respect to the earlier revision:

Last Manual Revision D2	Jan. 2004	-
This Manual Revision E (based on software 134-68)	Feb. 2004	In section 10.0 on Parameter, the function for selecting decimal point position is withdrawn. A new function is introduced to set the speed of running the ADC. There are now 4 printing options which can be set with the desired baud rate.

CONTENTS

1.0	INTRODUCTION	3
2.0	SPECIFICATIONS	4
3.0	INSTALLATION	6
3.1	LOCATING THE SCALES.....	6
3.2	SETTING UP THE SCALES	6
4.0	KEY DESCRIPTIONS.....	7
5.0	DISPLAYS	8
5.1	WEIGHT DISPLAY.....	8
5.2	UNIT WEIGHT DISPLAY	9
5.3	COUNT DISPLAY	9
6.0	OPERATION.....	10
6.1	ZEROING THE DISPLAY.....	10
6.2	TARING.....	10
6.3	PARTS COUNTING	12
6.3.1	Setting Unit Weight	12
6.3.2	Weighing a sample to determine the Unit Weight.....	12
6.3.3	Entering a known Unit Weight.....	13
6.3.4	Automatic part weight.....	14
6.3.5	Count pre-set or check-weighing.....	14
6.3.6	Manually accumulated total.....	14
6.3.7	Automatic accumulated total	15
7.0	BATTERY OPERATION	15
8.0	BACKLIGHT CONTROL	16
9.0	RS-232 OUTPUT	17
10.0	PARAMETERS	18
11.0	CALIBRATION	19
12.0	ERROR CODES	20

1.0 INTRODUCTION

- The **TFC** range of scales provides an accurate, fast and versatile counting and check-weighing scales.
- There are 2 series of scales within the range. **TFC** scales are Kilogram only scales and the **TFCa** scales are changeable from pounds to kilograms.
- The scales in these series share the same functions but special instructions will be given for the **TFCa** series to be able to change the weighing units.
- There are 3 models in each series with capacities up to 300 kg./660 lb.
- They all have stainless steel weighing platforms on a Steel base assembly and a display module mounted on a pillar attached to the base.
- All the keypads are sealed, colour coded membrane switches and the displays are large easy to read liquid crystal type displays (LCD). The LCD's are supplied with a backlight.
- All units include automatic zero tracking, audible alarm for pre-set weights, automatic tare, pre-set tare and an accumulation facility that allows the count to be stored and recalled as an accumulated total.

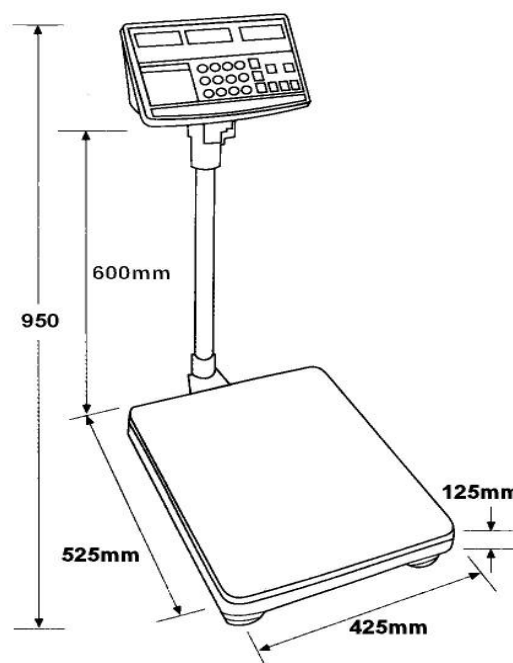

2.0 SPECIFICATIONS

TFC SERIES			
Model #	TFC 60	TFC 150	TFC 300
Maximum Capacity	60 kg	150 kg	300 kg
Readability	5 g	10 g	20 g
Resolution	1:15.000	1:15.000	1:15.000
Minimum Capacity	100 g	200 g	400 g
Repeatability (Std Dev)	5 g	10 g	20 g
Linearity \pm	10 g	20 g	40 g
Units of Measure	kg		

TFCa SERIES			
Model #	TFC 130a	TFC 330a	TFC 660a
Maximum Capacity	130 lb/60 kg	330 lb/150 kg	660 lb/300 kg
Readability	0.01 lb/5 g	0.02 lb/10 g	0.05 lb/20 g
Resolution	1:13,000 / 1:15.000	1:16,500 / 1:15.000	1:13,200 / 1:15.000
Tare range	-100 lb/-60 kg	-330 lb/-150 kg	-660 lb/-300 kg
Minimum Capacity	0.2 lLb/100 g	0.4 lb/200 g	1 lb/400 g
Repeatability (Std Dev)	0.01 lb/5 g	0.02 lb/10 g	0.05 lb/20 g
Linearity \pm	0.02 lb/10 g	0.04 lb/20 g	0.10 lb/40 g
Units of Measure	lb/kg		

Common Specifications

Interface	RS-232 Output Optional
Stabilisation Time	2 Seconds typical
Operating Temperature	0°C - 40°C 32°F - 104°F
Power supply	9 VDC from external power supply
Calibration	Automatic external
Display	3 x 6 digits LCD digital display
Draft shield	N/A
Balance Housing	Indicator ABS Plastic, Base Steel with Stainless Steel platform
Pan Size	425 mm x 525 mm / 16.7" x 20.7"
Overall Dimensions (wxdxh)	425 mm x 700 mm x 950 mm / 16.7" x 27.5" x 37.5"
Gross Weight	28 kg/62 lb
Applications	General Purpose Parts counting Scale
Functions	kilogram weight, parts counting, accumulating memory, preset count with alarm
Other Features and Specs	accuracy enhancement for parts counting, internal rechargeable battery (~70 hours operation)

3.0 INSTALLATION

3.1 LOCATING THE SCALES

- The scales should be sited in a location that will not degrade the accuracy.
- Avoid extremes of temperature. Do not place in direct sunlight or near air conditioning vents.
- Avoid unsuitable tables. The tables or floor must be rigid and not vibrate. Do not place near vibrating machinery.
- Avoid unstable power sources. Do not use near large users of electricity such as welding equipment or large motors.
- Avoid high humidity that might cause condensation. Avoid direct contact with water. Do not spray or immerse the scales in water.
- Avoid air movement such as from fans or opening doors. Do not place near open windows.
- Keep the scales clean.
- Do not stack material on the scales when they are not in use.

3.2 SETTING UP THE SCALES

- The pillar is attached to the base using a bracket that must first be attached to the base frame using the 4 bolts supplied. The Pillar is secured to the bracket using 2 set screws. The cable from the base to the indicator module is run through the tube, out through the plastic support at the top. Excess cable can be stored within the tube.
- The TFC Series comes with a stainless steel platform packed separately. Place the platform in the base.
- Level the scale by adjusting the four feet. The scale should be adjusted such that the bubble in the spirit level is in the centre of the level and the scale is supported by all four feet. If it rocks re-adjust the feet.

- Attach the indicator module to the pillar by sliding it over the bracket with the flanges engaged in the groves on the base. Attach the cable from the base to the connector on the rear of the indicator.
- Attach the power supply module to the connector on the side of the indicator. The power switch is located next to the connector.

4.0 KEY DESCRIPTIONS

[0-9, .]

Numeric entry keys, used to manually enter a value for tare weights, unit weight and sample size.

[CE]

Used to clear the unit weight or an erroneous entry.

[Zero] or

Set the zero point for all subsequent weighing. The display shows zero.

[Tare] or

Tares the scale. Stores the current weight in memory as a tare value, subtracts the tare value from the weight and shows the results. This is the net weight. Entering a value using the keypad will store that value as the tare value.

[M+] or

Add the current count to the accumulator. Up to 99 values or full capacity of the weight display can be added.

[MR]

To recall the accumulated memory.

[Smpl] or

To enter the number of items of a sample.

[Unit Wt] or

To enter the weight of a sample manually.

TFCa SCALES ONLY

Kg/Lb key in place of Unit Weight key.

This key will select the weighing unit when the unit weight display is at zero or acts as the Unit Wt key to enter known unit weights manually.

[PST] or



To set the upper limit for the number of items counted. When this upper limit is exceeded the scale will sound the beeper. Backlight control setting.

[Print] or 

To print the results to a PC or printer using the optional RS-232 interface.

5.0 DISPLAYS

The scales have three digital displays- **Weight**, **Unit Weight** and **Count**.

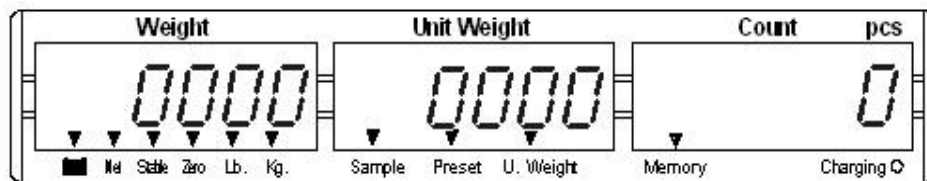

TFCa
Type
with lb/kg
indicators

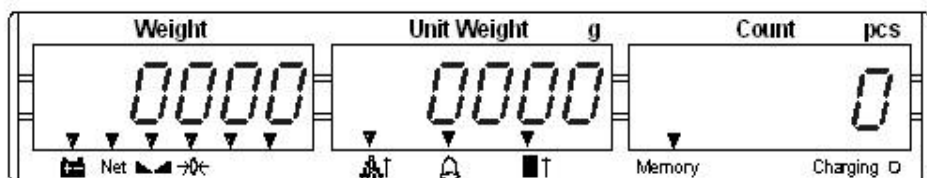

TFC Type
with
symbols

5.1 WEIGHT DISPLAY

This consists of a 5 digit display to indicate the weight on the scale.

Arrows above symbols will indicate the following:

Low battery,





Net Weight Display, "Net"

Stability indicator, "**Stable**" or 

Zero Indicator, "**Zero**" or 

And in the **TFCa** models indications for kilogram "**kg**" or Pound "**lb**" units.

5.2 UNIT WEIGHT DISPLAY

- This display will show the unit weight of a sample. This value is either input by the user or computed by the scale. The unit of measure is grams on all scales with kilogram weight units or in pounds on scales that show pounds.
- When the scale has determined that there is insufficient number of samples to accurately determine the count, the indicator will show at "**Sample**" or  symbol.
- When the unit weight is not large enough to determine an accurate count, the indicator will show at "**U. Weight**" or  symbol.
- In both the cases the scale continues to operate and the indications are to alert the user to a potential problem.
- If a preset count has been stored the "**Preset**" or  symbol will have an arrow above it.

5.3 COUNT DISPLAY

- This display will show the number of items on the scale or the value of the accumulated count. See OPERATION section.
- When a value has been entered into the memory, the arrow above the "**Memory**" legend will be on.
- Just under the "**Count**" display is an LED to indicate the status of battery charging. When the scale is plugged into the main power the internal battery will be charged. If the LED is green, the battery has a full charge. If it is Red, the battery requires further charging and yellow indicates the battery is being charged.

6.0 OPERATION

6.1 ZEROING THE DISPLAY

- You can press the **[Zero]** key at any time to set the zero point from which all other weighing and counting is measured. This will usually be necessary only when the platform is empty. When the zero point is obtained the "**Weight**" display will show the indicator at zero.
- The scale has an automatic re-zeroing function to account for minor drifting or accumulation of material on the platform. However you may need to press **[Zero]** to re-zero the scale if small amounts of weight are shown when the platform is empty.

6.2 TARING

There are two methods to enter a tare value. The first uses the weight on the platform and the second uses a value input by the user.

First Method:

- Zero the scale by pressing the **[Zero]** key, if necessary. The zero indicator will be on.
- Place a container on the platform, a value for its weight will be displayed.
- Press the **[Tare]** key to tare the scale. The weight that was displayed is stored as the tare value and that value is subtracted from the display, leaving zero on the display. The "**Net**" indicator will be on. As product is added only the net weight of the product will be shown. The scale could be tared a second time if another type of product was to be added to the first one. Again only the weight that is added after taring will be displayed.
- When the container is removed a negative value will be shown. If the scale was tared just before removing the container this value is the gross weight of the container plus all products those were removed. The zero indicator will also be on because the platform is back to the same condition as it was when the **[Zero]** key was last pressed.

Second Method:

- This method allows you to enter a value for the tare weight from the keypad. This is useful if all containers are the same or if the container is already full but the net weight is required and the tare weight of the container is known.
- Remove all weights from the platform, press the **[Zero]** key to zero the display.
- Enter the value for the Tare weight including decimal point using the keypad, press **[Tare]** to store the tare value. The weight will show a negative value equal to the tare.
- Place the container on the platform.
- The display will then show the weight of the container minus the tare weight. When the full container is placed on the platform the tare value will be subtracted from the gross weight displaying only the net weight of the contents.
- If the value input is not consistent with the increment of the scale, the scale will round the tare value to the nearest value possible. For example if a tare value of 103g is entered onto the 60Kg/5g scale then the display will show -105g.

TFCa SERIES ONLY

SETTING THE WEIGHING UNIT

The scale will turn on displaying the last weighing unit selected, either kilograms or pounds. To change the weighing unit press the **[Lb/Kg]** key when the “**Unit Weight**” display shows zero. If necessary press the **[CE]** key to clear the unit weight before changing. If the unit weight display is not at zero then the scale uses the value in the display to set a new unit weight.

6.3 PARTS COUNTING

6.3.1 Setting Unit Weight

In order to do parts counting it is necessary to know the average weight of the items to be counted. This can be done by weighing a known number of the items and letting the scale determine the average unit weight or by manually inputting a known weight using the keypad.

6.3.2 Weighing a sample to determine the Unit Weight

- To determine the average weight of the items to be counted it will be necessary to place a known quantity of the items on the scale and then to key in the quantity being weighed.
- The scale will then divide the total weight by the number of samples and display the average unit weight.
- Zero the scale by pressing the **[Zero]** key if necessary. If a container is to be used, place the container on the scale and tare as discussed earlier.
- Place a known quantity of items on the scale. After the **"Weight"** display is stable enter the quantity of items using the numeric keys followed by pressing the **[Smpl]** key. The number of units will be displayed on the **"Count"** display and the computed average weight will be shown on the **"Unit Weight"** display.
- As more items are added to the scale, the weight and the count will increase.
- If the scale is not stable, the calculation will not be completed. If the weight is below zero, the **"Count"** display will show negative count.

6.3.3 Entering a known Unit Weight

- If the unit weight is already known then it is possible to enter that value using the keypad.
- Enter the value of the unit weight using the numeric keys followed by pressing the **[Unit Wt]** key. The "**Unit Weight**" display will show the value as it was entered.
- The sample is then added to the scale and the weight will be displayed as well as the quantity based upon the unit weight. When weighing in kilograms the unit weight is shown in grams. When weighing in pounds the unit weight is shown in pounds.

TFCa Series only:

The **[Unit Wt]** key is labelled with **lb/kg** as this key has a dual function. When the scale is at zero and the "**Unit Weight**" display is showing zero, pressing the key will change the weighing unit from pounds to kilograms. When a value is entered into the "**Unit Weight**" display, this key is not active for changing the weighing units and the scale will automatically use the value for the unit weight if the **[Unit Wt]** key is pressed within 5 seconds.

- After the unit weight has been determined or entered it is possible to use the scale for parts counting. The scale can be tared to account for the package weight as discussed in an earlier section.
- After the scale is tared, the items to be counted are added and the "**Count**" display will show the number of items computed using the weight and the unit weight.
- It is possible to increase the accuracy of the unit weight at any time during the counting process by entering the count displayed and then pressing the **[Smpl]** key. You must ensure that the quantity displayed matches the quantity on the scale before pressing the key. The unit weight will be adjusted based upon a larger sample quantity. This will give greater accuracy when counting larger sample sizes.

6.3.4 Automatic part weight

- The scales will automatically update the unit weight when a sample equal to or less than the sample already on the platform is added. A beep will be heard when the value is updated. It is wise to check the quantity is correct when the unit weight has been updated automatically.
- This feature is turned off as soon as the number of items added exceeds the count used as a sample.

6.3.5 Count pre-set or check-weighing

- Check-weighing (Count Pre-setting) is a procedure to cause an alarm to sound when the number of items counted on the scale meets or exceeds a number stored in memory, by using the **[Pst]** key.
- The stored value is entered from the keyboard. Enter the numeric value to be stored using the numeric keys. Then press the **[Pst]** key to store the value.
- To clear the value from memory and thereby turn off the check-weighing feature, enter the value "0" into the memory.

6.3.6 Manually accumulated total

- The values (weight and count) shown on the display can be added to the values in the accumulator by pressing the **[M+]** key. The "**Weight**" display will show the total weight, the "**Count**" display will show the total accumulated count and the "**Unit Weight**" display shows the number of times items have been added to the accumulation memory. The values will be displayed for 2 seconds before returning to normal.
- The scale must return to zero or a negative number before another sample can be added to the memory.
- More products can then be added and the **[M+]** key pressed again. This can continue for up to 99 entries or until the capacity of the "**Weight**" display is exceeded.

- To observe the total value stored, press the **[MR]** key. The total will be displayed for 2 seconds.
- To clear the memory, first press **[MR]** to recall the total from the memory and then press **[CE]** to clear all values from the memory.

6.3.7 Automatic accumulated total

- The scale can be set to automatically accumulate total when a weight is placed on the scale. This eliminates the need to press the **[M+]** key to store values into the memory. However the **[M+]** key is still active and can be pressed to store the values immediately. In this case, the values will not be stored when the scale returns to zero.
- See the PARAMETERS Section for details on how to enable Automatic Accumulation.

7.0 BATTERY OPERATION

- The scales can be operated from the battery if desired. The battery life is approximately 70 hours.
- When the battery needs charging the arrow above the low battery symbol under the “**Weight**” display will turn on. The battery should be charged as soon as the arrow above the symbol is on. The scale will still operate for about 10 hours after which it will automatically switch off to protect the battery.
- To charge the battery simply plug into the mains power. The scale does not need to be turned on.
- The battery should be charged for 12 hours for full capacity.

- Just under the “**Count**” display is an LED to indicate the status of battery charging. When the scale is plugged into the main power the internal battery will be charged. If the LED is green the battery has a full charge. If it is Red, the battery is nearly discharged and yellow indicates the battery is being charged.
- As the battery is used it may fail to hold a full charge. If the battery life becomes unacceptable then contact your distributor or Adam Equipment.

8.0 BACKLIGHT CONTROL

- The backlight of the LCD can be set to be **ON** full time, **ON** only when a weight is on the scale or turned to **OFF**.
- To set the backlight press and hold the [**PST**] key for 4 seconds.
- The weight display will show “**EL xx**” where **xx** is the current setting for the backlight.
- Enter a value of 1, 2 or 3 to set the parameter.
- Press [**1**], “**EL AU**” sets the backlight to operate automatically when a weight is placed on the scale or a key is pressed.
- Press [**2**], “**EL Off**” sets the backlight to be **OFF**.
- Press [**3**], “**EL on**” sets the backlight to be **ON** at all times.
- Press the [**Tare**] key to store the value or press the [**Zero**] key to escape from this setting and return to weighing.

9.0 RS-232 OUTPUT

The **TFC** series of scales can be ordered with an optional RS-232 output.

Specifications:

RS-232 output of weighing data
ASCII code
4800 Baud
8 data bits
No Parity

Connectors:

25 pin d-subminiature socket
Pin 2 Output
Pin 3 Input, not used at this time
Pin 7 Signal Ground

Data Format: Normal Output

GS 123.4 Kg GS for Gross weight, NT for net weight, (with tare value stored)
U.W. 123 g Kg and g for metric and Lb for pounds.
PCS 1000 pcs
<lf> Includes 2 line feeds
<lf>

Data Format: Memory Recall Print

```
*****  
<lf>              Includes 1 line feed  
TOTAL  
No.            5  
Wgt 123.4 Kg    .  
PCS 1000 pcs  
<lf>              Includes 1 line feed  
*****
```

10.0 PARAMETERS

- To set the parameters it is necessary to enter a secure menu. This is done by entering a password number when requested.
- To enter the parameter menus press the **[Tare]** key during the initial counting of the display after power is turned on. The “**Weight**” Display will show “**Pin**” requesting the password number to be entered.
- The default password is “**0000**” but other numbers can be set using the parameter menus.
- Press the “**0**” key four times when the display shows “**Pin- - -**”, Press the **[Tare]** key again.
- The following functions can be accessed using the **[Unit Wt.]** key (**[Lb/kg]** key on **TFCa** series) to cycle through the choices. The “**Weight**” display will show the name of the functions. To enter a function, press the **[Tare]** key. At any time press the **[Zero]** key to return to weighing.

Display	Description
F1 CAL	See the calibration section for details
F2 dl	Set the scale increment. Press the [Unit Wt.] key to show the options. Press the [Tare] key to accept the selection.
F3 CAP	Select the scale capacity.
F4 Cnt	Displays the A/D counts. Press the [Tare] key to return to menu.
F5 Pin	Set a new password number. Display will show “ P1 ” Enter the new password number then press the [Tare] key. Display will change to “ P2 ”, Enter the password again and press [Tare] . The display will show “ done ” to show the new password has been accepted. Record the new password number in a secure place.
F6 Prt	Press the [Unit Wt.] key to show the following options. Select “ P Prt ” to have the scale print, whenever the [Print] key is pressed. Select “ P Auto ” to print anytime a weight is placed on the scale. Select “ SEI re ” to continuously print the weight only. Select “ P Cont ” for continuously printing of the unit weight, no. of pieces and the total weight. For each of these printing options, you can select the desired baud rate. This can be set by pressing [Unit Wt.] to scroll through the available baud rates (600, 1200, 2400, 4800 and 9600) and then press [Tare] to select any one of these and return to the main menu.
F7 SPd	This is used to set the speed at which the scale will run the ADC. The settings available are 7.5, 15, 30 and 60- the slowest setting being 7.5 and the fastest is 60.

11.0 CALIBRATION

- The **TFC** scales calibrate using metric weights and the **TFCa** scales can calibrate using either metric or pound weights, depending on the weighing unit in use before calibration.
- When the parameter menu shows "**F1 CAL**" press the **[Tare]** key.
- The display will then show "**unLoAd**" requesting for all weights to be removed from the platform.
- Press the **[Tare]** key to set the zero point.
- The display should then show the last calibration weight requested.
- If this weight is acceptable then press the **[Tare]** key to accept it, or enter a new calibration weight using the keypad and then press the **[Tare]** key. To calibrate at 100.00 Kg simply type 100. Do not type the decimal place followed by zeros.
- The display will show "**LOAd**". Place the calibration weight on the scale and press the **[Tare]** key. The scale will calibrate and then start the initial self-check procedure counting from 9 to 0. Remove the weight during the counting.

TFCa scales will also have the lb or kg indicator **ON** to show the denomination of the weight requested. If the scale was in pounds before starting calibration the weights requested will be in pound values or if the scale was weighing in kilograms then metric weights will be requested.

- If an error message "**Err 8**" is shown during calibration re-check the calibration and repeat it if necessary. If the problem persists then contact Adam Equipment or your dealer for further assistance.
- After calibration, you should check whether the calibration and the linearity are correct. If necessary repeat calibration, ensure that the scale is stable before accepting any weight.

12.0 ERROR CODES

During the initial power-on testing or during the operation, the scale may show an error message. The meaning of the error messages are described below.

If an error message is shown, repeat the procedure that caused the message, such as turning the balance on, calibration or any other functions. If the error message is still shown then contact your dealer for further support.

ERROR CODE	DESCRIPTION	POSSIBLE CAUSES
Err 4	Initial Zero is greater than the permissible value (typically 4% of maximum capacity) when power is turned on or when the [Zero] key is pressed,	Weight on the pan when turning the scale on. Excessive weight on the pan when zeroing the scale. Improper calibration of the scale. Damaged load cell. Damaged Electronics.
Err 5	Keyboard error.	Improper operation of the scale.
Err 6	A/D count is not correct when turning the scale on.	Platform is not installed. Load cell may be damaged. Electronics may be damaged.
Err 8	Calibration error	Improper calibration. The scale may not be stable.



Manufacturer's Declaration of Conformity

This product has been manufactured in accordance with the harmonised European standards, following the provisions of the below stated directives:

Electro Magnetic Compatibility Directive 89/336/EEC

Low Voltage Directive 73/23/EEC

Adam Equipment Co. Ltd.
Bond Avenue
Denbigh East Estate
Milton Keynes, MK1 1SW
United Kingdom

FCC COMPLIANCE

This equipment has been tested and found to comply with the limits for a Class A digital device, pursuant to Part 15 of the FCC Rules. These limits are designed to provide reasonable protection against harmful interference when the equipment is operated in a commercial environment. The equipment generates, uses, and can radiate radio frequency energy and, if not installed and used in accordance with the instruction manual, may cause harmful interference to radio communications. Operation of this equipment in a residential area is likely to cause harmful interference in which case the user will be required to correct the interference at his own expense.

Shielded interconnect cables must be employed with this equipment to insure compliance with the pertinent RF emission limits governing this device.

Changes or modifications not expressly approved by Adam Equipment could void the user's authority to operate the equipment.

ADAM EQUIPMENT is an ISO 9001:2002 certified global organisation with more than 30 years experience in the production and sale of electronic weighing equipments. Products are sold through a world wide distributor network –supported from our company locations in the UK, USA and SOUTH AFRICA. The company and their distributors offer a full range of Technical Services such as on site and workshop repair, preventative maintenance and calibration facilities.

ADAM's products are predominantly designed for the Laboratory, Educational, Medical and Industrial Segments. The product range can be classified as follows:

- Analytical and Precision Laboratory Balances
- Top Loading Balances for Educational establishments
- Counting Scales for Industrial and Warehouse applications
- Digital Weighing/Check-weighing Scales
- High performance Platform Scales with extensive software features including parts counting, percent weighing etc.
- Digital Electronic Scales for Medical use
- Retail Scales for price computing

<p>Adam Equipment Co. Ltd. Bond Avenue Milton Keynes MK1 1SW UK</p> <p>Phone: +44 (0)1908 274545 Fax: +44 (0)1908 641339</p> <p>e-mail: sales@adamequipment.co.uk</p>	<p>Adam Equipment Inc. 26, Commerce Drive Danbury, CT 06810 USA</p> <p>Phone: +1 203 790 4774 Fax: +1 203 792 3406</p> <p>e-mail: sales@adamequipment.com</p>	<p>Adam Equipment S.A. (Pty) Ltd. P.O. Box 1422 Kempton Park 1620 Johannesburg Republic of South Africa</p> <p>Phone +27 (0)11 974 9745 Fax: +27 (0)11 392 2587</p> <p>e-mail: sales@adamequipment.co.za</p>
--	--	---

© Copyright by Adam Equipment Co. Ltd. All rights reserved. No part of this publication may be reprinted or translated in any form or by any means without the prior permission of Adam Equipment.

Adam Equipment reserves the right to make changes to the technology, features, specifications and design of the equipment without notice.

All information contained within this publication was to the best of our knowledge timely, complete and accurate when issued. However, we are not responsible for misimpressions which may result from the reading of this material.

The latest version of this publication can be found on our Website.

Visit us at www.adamequipment.com