

# Brecknell

860 series



an unbeatable package for the independent retailer

# Brecknell 860 series electronic scales

The Brecknell **860** is a price-computing scale that offers an unbeatable package for the independent retailer and is designed to offer all the functions your business needs.

◆ **Euro compatibility**

The Euro exchange rate can be set quickly and simply, enabling unit and total prices to be displayed in either local or Euro currency, at the touch of a button.

◆ **Stylish, compact and tough**

The **860** is attractively designed and is tough enough to withstand everyday professional use. It offers the perfect combination of a compact footprint and a spacious weighplate manufactured in high quality stainless steel. Additional fittings are available.

◆ **Instore or outdoors - You've got the power**

The **860** gives you the power to use your scale in most trading situations, by offering a choice of mains or battery power. Take advantage of the battery option, and the **860** is instantly portable, offering up to 800 hours\* of continuous operation without the need to recharge or replace the batteries. Further battery options are also available.

\* Subject to the quality of batteries used.

◆ **Choice of display**

The **860** offers a wide choice of display options. The customer tower display makes effective use of counter space and features a highly visible LCD display, to ensure that price and weight information remain prominent. Back lit display options are also available. A range of other functions including seven-digit unit price, eight-digit total price, price per kg/ per 100 g are available.

◆ **PLU options**

The **860** can offer 20 pin-protected PLU's as standard - including up to 10 'hot shot' keys for favourites. These may be used with a 'quick-set' feature for fast-selling items.

◆ **Capacity options**

Whatever you want to weigh, from delicate items to product in bulk, the **860** delivers the capacity and resolution you need. From 3 kg up to 15 kg, in a choice of resolutions to meet your requirements.

◆ **International approvals**

## Dimensions

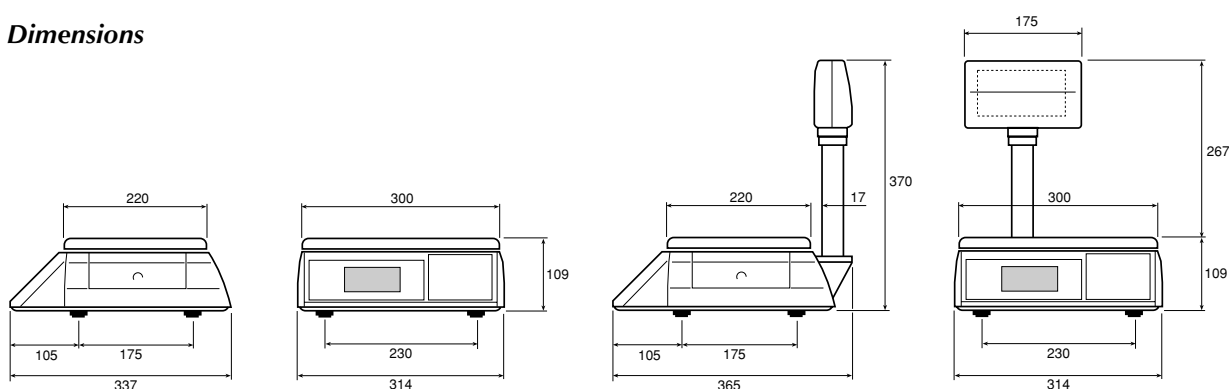

This brochure contains a general guide only of the product and shall not form part of any contract unless specifically agreed by Brecknell in writing in each case on the Order Acknowledgement. The specification of the products described herein may vary from time to time and may be altered without notice.



Your local stockist is:

Foundry Lane, Smethwick, West Midlands, England B66 2LP.  
Telephone: 0870 90 34343  
Fax: 0121-555 6062